

## UL400 Series Intrinsically Safe Transducer



- Eliminate Drift – Fused Bond sensor technology for long term stability
- Sensor wetted material machined from solid stainless steel bar stock – no welding
- No silicone oil fill, no internal o-rings, no welded diaphragms
- RFI/EMI protection on every transducer
- Outputs: 4-20mA, 1-5 Vdc and 1-6 Vdc
- Pressure ranges: 0-5 PSI to 10,000 PSI
- Standard accuracy of 0.25% BFSL
- Approved to UL 913 (CSA 157) for Class 1, Div 1, Groups C and D when used with suitable intrinsic safety barrier.
- Optional external Zero & Span controls (Model UL410)



Spectre's Series UL410 and UL440 Intrinsically Safe Pressure Transducers are specifically engineered with proprietary Fused Bond sensor technology to eliminate the two most common problems with pressure transducers, noise and drift. The UL410 and UL440 (with zero & span) are approved to UL 913 (CSA 157) for use in Class 1, Div 1, Group C & D hazardous areas when used with a suitable safety barrier

### Performance @ 25°C (77°F)

Accuracy:  $<\pm 0.25\%$  BFSL  
Stability (1 year):  $<\pm 0.25\%$  FS, typical  
Over pressure protection: 2X Rated Pressure  
Burst Pressure: 5X or 20,000 PSI (whichever is less)  
Pressure Cycles: >100 Million  
Temperature range: -55 to +125°C (-65 to +250°F)  
Temperature Accuracy:  $\pm 1^\circ\text{C}$  ( $\pm 1^\circ\text{F}$ )

### Environmental Data

Operating temp: -40 to +85°C (-40 to +185°F)  
Storage temp: -50 to +125°C (-60 to +250°F)  
Compensated range: 0 to 55°C (-32 to +130°F)  
Temp comp Zero:  $<\pm 1.5\%$  FS  
Temp comp Span:  $<\pm 1.5\%$  FS

### Electrical Data

Excitation: 10-26 Vdc  
Output: 4-20mA, 1-5 Vdc, 1-6 Vdc  
Current consumption:  $<5\text{mA}$   
Zero offset:  $<\pm 1\%$  of FS  
Span tolerance:  $<\pm 1\%$  of FS  
Output load: 5K Ohm (voltage)  
800 Ohm@24 Vdc (4-20mA)

### Physical data

Sensor wetted material: 17-4 PH stainless (316SS optional)  
Pressure Connection: 1/4" & 1/8" MNPT, SAE-4  
Electrical connection: 24" leads, 1/2" MNPT conduit connection, DIN 43650  
Shock: 100G, 11msec; 1/2 sine  
Vibration: 10G peak, 20 to 2000 Hz  
ANSI/ISA 12.27.01-2003 Compliant

## UL400 Series Intrinsically Safe Transducer

Ordering guide – Example: UL440-A-(0-100PSI)-2-A-EC9-174

UL440	A	0-100PSI	2	A	EC9	174
Model	Pressure port	Range	Units	Output	Connector	Material
UL410 (with zero and span) UL440	A=1/4" MNPT B=SAE-4 C=1/8" MNPT	Specify pressure range in: PSI (5-10,000)	2=Gauge 4=Sealed 5=Compound 6=Other	A=4-20mA B=1-5Vdc C=1-6Vdc	EC1=24" wiring Leads EC2=Large DIN EC3=Mini DIN EC9=1/2"MNPT w/24" leads ECX=Other	174=17-4 ss 316=316 ss

### Dimensions: Model UL440

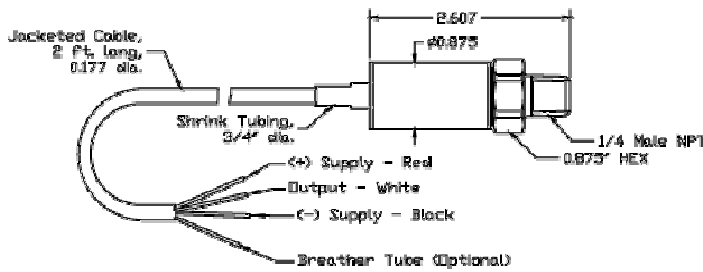

Wiring	4-20mA output, Cable
White	+ excitation
Black	- excitation/signal
Power	10-28 Vdc

Wiring	Voltage output, Cable
Red	+ excitation
White	- signal
Black	- excitation/signal
Power	10-28 Vdc

### Dimensions: Model UL410

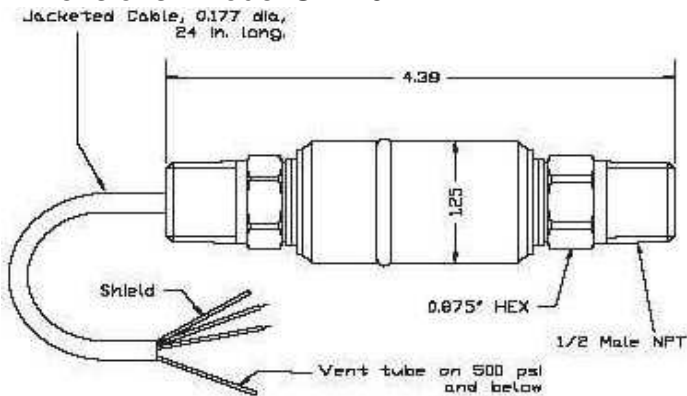

Above dimensions may vary with options. Specifications subject to change without prior notice.

Entity Parameters	Notes
Vmax=28 VDC Imax=150mA C1=0.44uf L1=0 Imax is the total current consumption available from the Associated Apparatus under any condition	1) Associated Apparatus shall provide intrinsically safe connections which meet the following parameters: $V_{oc} \text{ or } V_t \leq V_{max}$ $C_a \geq C_1 + C_{leads}$ $I_{sc} \text{ or } I_t \leq I_{max}$ $L_a \geq L_1 = L_{leads}$ 2) Control room apparatus shall not generate in excess of 250V (Umax) 3) Installation should be in accordance with Article 504 in the National Electrical Code, ANSO/NFPA 70

Spectre Sensors, Inc.  
 32357 Walker Road  
 Avon Lake, OH 44012-2224  
 www.spectresensors.com

Phone: 440-930-5699  
 Fax: 440-930-5668  
 e-mail: info@spectresensors.com