

Model S950 Precision Sanitary Series

Pressure/Temperature Transducer



- Transducer is customized to your specific temperature and pressure conditions.
- Maximum RF/EMI protection supplied as standard
- All welded stainless steel construction
- Outputs - 4-20mA, 0-5V, 0-10V, TC, RTD, RS232, RS485, USB 2.0
- Pressure ranges 0-10"WC to 0-1,000 PSI
- Accuracies to 0.03% BFSL
- Unparalleled long-term stability
- Temperature compensation at the sensor element.
- Custom designs available (contact factory)



Spectre's S950 Sanitary Series Pressure Transducers offer the first available sensors that are manufactured, designed and calibrated to each customer's specific operating conditions. The Model S950 is ideal for critical pharmaceutical and chemical applications where product contamination is unacceptable.

Each Model S950 transducer output is digitally mapped to correct for any non-linearity or inaccuracies in the sensor.

Performance @ 25°C (77°F)

Accuracy: $<\pm 0.05\%$ BFSL (0.03% optional)
Stability (2 year): $<\pm 0.05\%$ FS, typical
Over pressure protection: 2X Rated Pressure
Burst Pressure: 2.5X minimum
Pressure Cycles: >50 Million
Temperature range: -40 to +100°C (-40 to + 212°F)
Optional: -60 to + 130°C (-76 to +266°F)
Temperature Accuracy: $\pm 1^\circ\text{C}$ ($\pm 1^\circ\text{F}$)

Environmental Data

Operating temp: -40 to + 85°C (-40 to +185°F)
(Optional to +275°F – consult factory)
Storage temp: -50 to +125°C (-60 to +250°F)
Compensated range: 0 to 50°C (+32 to +125°F)
Temp comp Zero: $<\pm 1.5\%$ FS
Temp comp Span: $<\pm 1.5\%$ FS

Electrical Data

Excitation:
9-36 Vdc (4-20mA and 0-5 Vdc outputs)
13-36 Vdc (0-10 Vdc output)
Option: C29: Maximum 29 Vdc excitation
Current consumption: <5 mA (voltage outputs)
Zero offset: $<\pm 0.25\%$ of FS
Span tolerance: $<\pm 1.0\%$ of FS
Output load: $>100\text{K}$ Ohm

Physical data

Sensor wetted material: 316 stainless steel)
Pressure connection: 2" Tri-clover
(other sizes optional)
Electrical Connection: Cable, DIN, Cannon, Bendix
(others available on application)

Spectre Sensors

Model S950 Precision Sanitary Series

Pressure/Temperature Transducer

Ordering guide – Example: S950-D-(0-500PSI)-2-D-1-05-EC1

D Pressure Port	(0-500) Range	2 Units	D Pressure Output	1 Temperature Output	5 Accuracy BFSL*	EC1 Connector
C=1.5" D=2" E=2.5" F=3"	Specify Pressure Range in PSI, BAR or kPa	1=Absolute 2=Gauge 3=Vacuum 4=Sealed 5=Compound 6=Other	D=4-20mA E=0-5VDC F=0-10VDC G=RS232 H=RS485 UC=USB 2.0 X=Other	0=None 1=4-20mA 2=0-5VDC 3=Thermocouple (specify J or K) 4=RTD, 100 ohm Platinum, 2-wire. X=Other	05=0.05% 03=0.03%	EC1=36" pigtail EC2=DIN 43650 with mate-Large EC3=Mini DIN EC4=Bendix 6-pin EC8=J-box with terminal block EC9=1/2" NPT conduit connection with 36" leads UA=USB "A" male with 4' cable

*BFSL = Best Full Scale Line

Dimensions

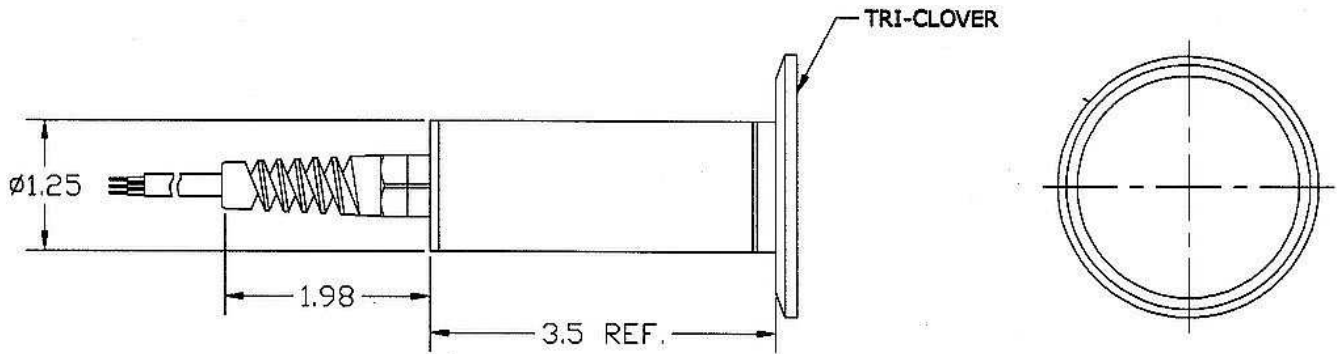

OPTIONS MAY CHANGE OVERALL DIMENSIONS,
CONSULT FACTORY

Spectre Sensors, Inc.
32357 Walker Road
Avon Lake, OH 44012-2224
www.spectresensors.com

Phone: 440-930-5699
Fax: 440-930-5668
e-mail: info@spectresensors.com