

## Model 8100 ANCHOR Submersible Transducer



- Transducer is customized to your specific temperature and pressure conditions
- Outputs: 4-20mA, 0-5 Vdc, 0-10 Vdc. Optional RS232, RS485 and USB 2.0
- Pressure ranges – 0-1 PSI to 500 PSI
- Standard accuracy of 0.10% BFSL (optional 0.05%)
- Flow-through standoff design for problem applications
- Built-in, proprietary design, lightning and surge protection supplied as standard
- Unparalleled long-term stability
- Digital temperature correction at operating conditions
- Proprietary digital “AutoZero” / recalibration mode (optional)
- Field rangeable 5:1 (optional)



Spectre’s “ANCHOR” (Model 8100) submersible series of industrial pressure transducers is specifically designed to operate in applications that are problematic for traditional submersible level transmitters. The conditions encountered in many process sumps, sewage wet-wells and dirty applications may cause plugging and erroneous readings with standard designs. The ANCHOR has an oversized diaphragm and flow-through standoff which helps to prevent clogging and build-up which may cause inaccuracies. In addition, **each transducer’s output is digitally mapped to correct for any non-linearity or inaccuracies in the sensing element.** This digital correction provides the most accurate and flexible submersible transducer in the industry.

### Performance @ 25°C (77°F)

Accuracy:  $<\pm 0.10\%$  Best Fit Straight Line (BFSL)  
Stability (2 year):  $<\pm 0.05\%$  FS, typical  
Over pressure protection: 2X Rated Pressure  
Burst Pressure: 2.5X minimum  
Pressure Cycles:  $>50$  Million  
Temperature range:  $-55$  to  $+85^{\circ}\text{C}$  ( $-65$  to  $+185^{\circ}\text{F}$ )  
Temperature Accuracy:  $\pm 1^{\circ}\text{C}$  ( $\pm 1^{\circ}\text{F}$ )  
Total Error Band:  $\pm 1.5\%$  (includes zero, span, static accuracy and temperature)

### Environmental Data

Storage temp:  $-50$  to  $+125^{\circ}\text{C}$  ( $-60$  to  $+250^{\circ}\text{F}$ )  
Compensated range:  $1$  to  $30^{\circ}\text{C}$  ( $+33$  to  $+86^{\circ}\text{F}$ )

### Electrical Data

**Excitation:**  
6-36 Vdc - 4-20mA output  
9-36 Vdc - 0-5 Vdc output  
14-36 Vdc - 0-10 Vdc output  
Option C29: Max 29 Vdc excitation

Optional serial comms: RS232, RS485 and USB 2.0  
Zero offset:  $<\pm 0.2\%$  of FS  
Span tolerance:  $<\pm 0.2\%$  of FS  
Current consumption: 0.12 Watt  
Output load:  $>10\text{K Ohm}$

### Physical data

Sensor wetted material: 316SS  
Body material: 316SS

Pressure connection: Flush diaphragm with stand-off

Electrical Connection: Vented and non-vented Kynar cable  
(submersible disconnects on application)

## Model 8100 ANCHOR Submersible Transducer

Ordering guide – Example: 8100-A-(0-15 PSI)-2-D-05-SCV

A	(0-15 PSI)	2	D	05	SCV
Pressure Port	Range	Units	Output	Accuracy	Connector
A=Anchor	Specify pressure range in: inches (mm) water, feet (meters) water, PSI or BAR	1=Absolute 2=Gauge (vented cable) 4=Sealed 6=Other	D=4-20mA** E=0-5VDC F=0-10VDC G=RS232** H=RS485** UC=USB 2.0 X=Other	1=0.10% BFSL* 05=0.05% BFSL*	SCV= ½" MNPT with Vented Cable*** SCN= ½" MNPT w with Non-vented cable*** ECX=Other

\* BFSL= Best Fit Straight Line

\*\*Combination 4-20mA + Comms available – contact factory for details

\*\*\* Standard cable jacket is Kynar. Others available on request – contact factory.

### Dimensions:

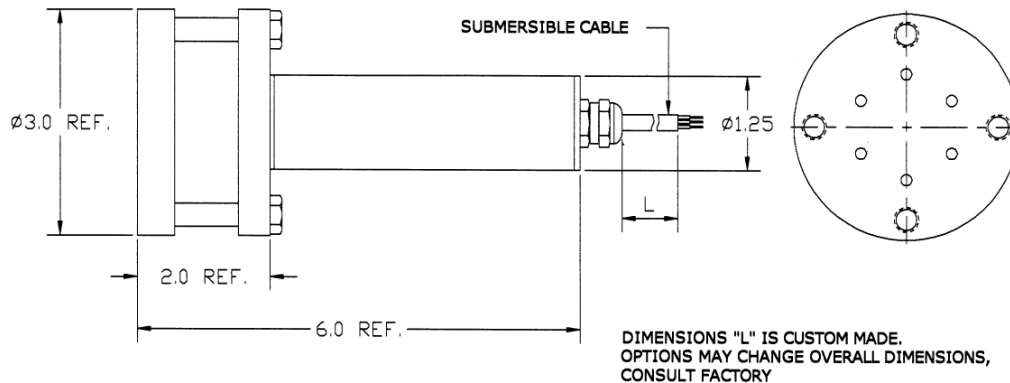

Wiring	4-20mA, Cable
White	+ excitation
Black	- excitation/signal
Power	6-32 Vdc

Wiring	Voltage, Cable
Red	+ excitation
Green	+ signal
Black	- excitation/signal
White	no connection
Output	Power
0-5 Vdc	9-32 Vdc
0-10 Vdc	13-32 Vdc

### Typical Applications:

- Ground Water Monitoring
- Wet-well Monitoring
- Ocean research
- Soil remediation
- Level Control
- Surface Water Monitoring