



## The Model 400T Series Temperature Sensor

Temperature Sensor with Transmitter

- Eliminate Drift – Microprocessor Technology Ensures Long-term Stability
- Eliminate Noise – High Signal / Noise Ratio
- 4-20mA, HART, Profibus & Foundation Fieldbus Outputs
- Cold Junction Compensation Available
- Suitable for High Temperature and Vibration
- Loop Powered or Bus-Powered Units
- Isolated and non-Isolated Models
- Weather Proof and Ex Area Approvals (FM, CSA, ATEX and UL)
- Accuracy of  $\pm 0.3$  Deg C Typical
- RTD or Thermocouple Sensors



### DESCRIPTION

Spectre's Fidelity series of Temperature sensors with combined head mount transmitters utilize the latest technology. RTD or thermocouple sensors are placed in a thermowell rated for the process conditions. A 2-wire programmable or fieldbus transmitter is then used to send the output signal. The units have an inherent shield that minimizes operational stops and increases productivity by providing the transmitter with a high basic accuracy, maximum protection against electromagnetic noise, and an extremely low temperature coefficient. This reliability is reflected in quality and stability that can be directly converted into cost-savings as your down time is eliminated.

### FEATURES

- Digital Microprocessor
- High Immunity to Conducted, HF and Burst Noise
- High Protection against energy loaded transients
- Extremely Low Temperature Coefficient of down to 0.002%
- Self Calibrating
- Sensor Error Alarm Action
- Unparalleled Long Term Stability

### DIMENSIONS

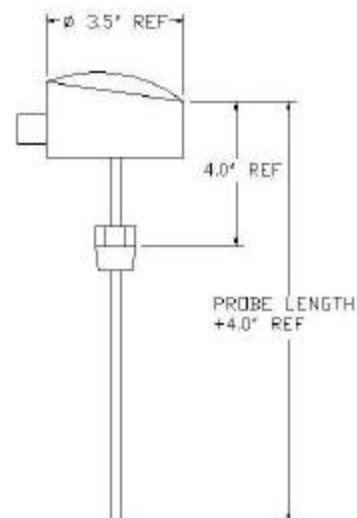

# Model 400T Series Temperature Sensor



Ordering Guide. Example: 400T-B-(32-500F)-1-S-D-2-WP

Please inquire for specials or options.

B	(32-500F)	1	S	D	2	WP
Process Connection	Temperature Range & Units	Sensor	Wetted Material	Output	Probe Length	Environmental Rating
A = 1/2" NPT (M) B = 1" NPT (M) C = 1.5" Tri-Clamp D = 2" Tri-Clamp E = 1" 150# Flange F = 2" 150# Flange X = Other	Specify Temperature Range & Units	1 = RTD PT100 2 = RTD PT1000 3 = TC (J) 4 = TC (K) X = Other	S = SS316L H = Hastelloy C M = Monel I = Inconel T = Titanium X = Other	D = 4-20mA E = HART F = Profibus G = Foundation Fieldbus	1 = 1" 2 = 2" 3 = 3" 4 = 4" 5 = 5" 6 = 6" 7 = 7"	WP = NEMA 4X IS = Intrinsically Safe for Class I, Div1, GR A-D.

## Performance @ 25°C (77°F)

Accuracy: $\pm 0.3$ Deg C, typical
Stability (5 year): $\pm 0.15 / 0.20\%$ , typical
Signal / Noise Ratio 80-100 db to attenuation factor of 10,000 – 100,000
Signal Dynamics Input: 18 bit Min
Temperature Range: -200 to 850°C (-325 to 1560°F)
Temperature Coefficient: $\pm 0.01\%$ of Span / Deg C

## Environmental Data

<b>Temperature</b>
Ambient: -40 to 85°C (-40 to 185°F)
Storage: -50 to 135°C (-60 to 275°F)

## Electrical Data

Supply: 8.0 - 35 Vdc
Output: 4-20mA, HART, Profibus, Foundation Fieldbus
Current Consumption: < 20mA
Voltage Drop < 8.0 Vdc
Max Offset: 50% of Selec. Max Value

## Physical Data

Sensor: RTD or Thermocouple
Process Connection: Standard or Custom
Electrical Connection: 1/2" NPT Conduit Port with Internal Terminal Block

## Applications:

The Model 400T has features that make it suitable for use in a wide variety of applications. The 400T was specifically designed to handle shock and vibration extremes.

## Contact Information

Spectre Sensors, Inc.  
1651-D Crossings Parkway  
Westlake, OH 44145  
877-297-6965 / Phone  
440-835-3599 / Fax  
[info@spectresensors.com](mailto:info@spectresensors.com)



**Spectre Sensors**